

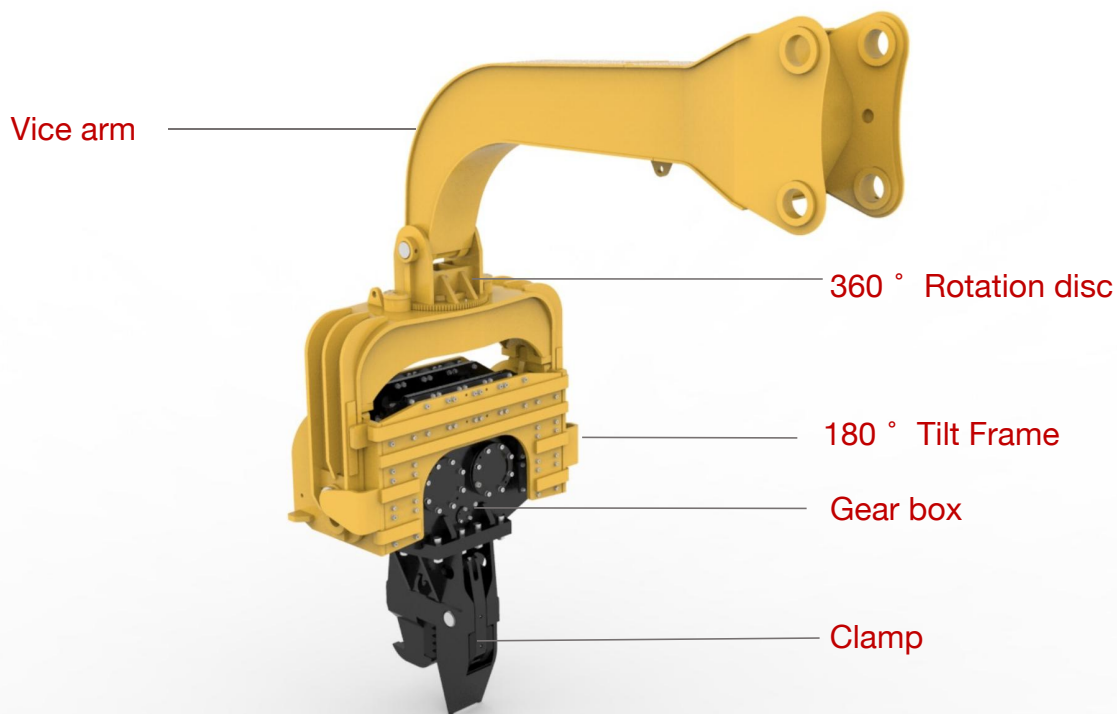

## EXCAVATOR MOUNTED VIBRATORY HAMMER

ANTENG pile drivers are excavator-mounted, high frequency, vibratory-type pile drivers - for handling, pitching, driving and extracting different type of piles in a wide range of site and soil conditions.

 **Fast**    
  **Stable**    
  **Efficient**    
  **Safe**



### FEATURES:

1. More environmentally friendly, more comfortable operation experience
2. Circulating cooling, no high temperature troubles
3. Full hydraulic flexible control, simple operation, 360 ° rotation, 180 ° tilt , pick up pile easily
4. Available for a wide range of piles including sheet piles, H-piles, tubular steel piles, timber piles etc.
5. Precise design ,reliable performance, core components are imported from famous brands.



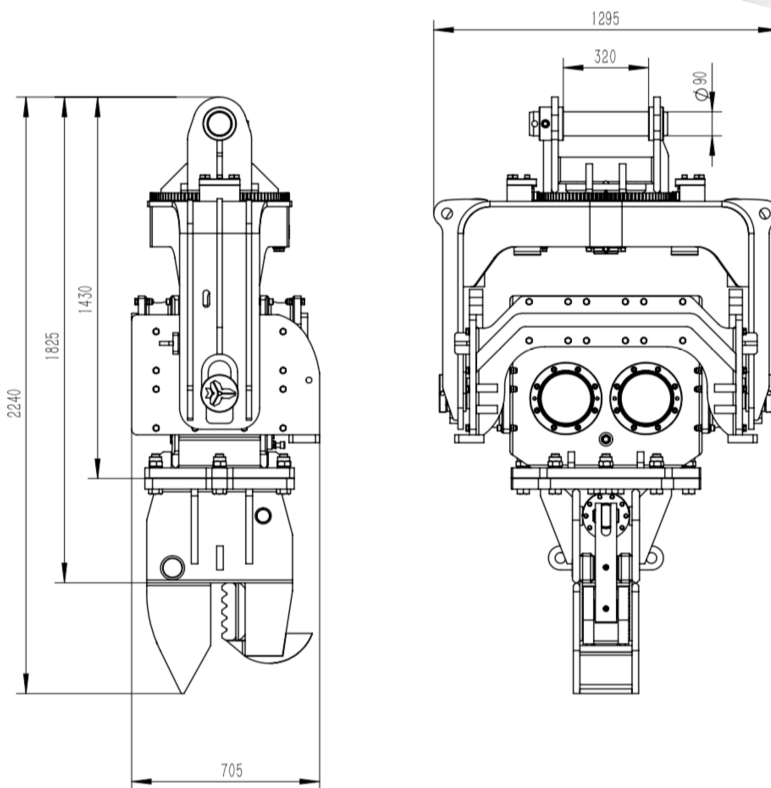

### V-250 SPECIFICATION

Eccentric Moment	Kgm	4.4
Frequency	rpm	2800
Centrifugal Force	Kn	333
Hydraulic system operation pressure	bar	280
Hydraulic system oil flow	lpm	164
Weight (with clamp and vice arm)	kg	2100+680
Suitable excavator weight	Ton	20-25
Size (measure with standard clamp)	mm	1300*705*2420
Vice arm model		A200
Standred Max. Applicable sheet pile length	m	6
Max. Applicable sheet pile length ( move down excavator boom cylinder)	m	8



#### V250 Application:

\*V250 Designed to match the capabilities of middle excavators and to combine a robust structure with excellent pile handling characteristics.

\* Fitted with clamps capable of driving a wide range of piles including sheet piles, H-piles, tubular steel piles and other pile sections.



#### NOTE!

! Preliminary selection. When making the final selection excavator engine size and hydraulic system design (oil pump arrangement, oil flow rate/pressure etc) as well as soil and site conditions shall be taken into account.

! Specifications are subject to change without notice.